

intelligent salt projects

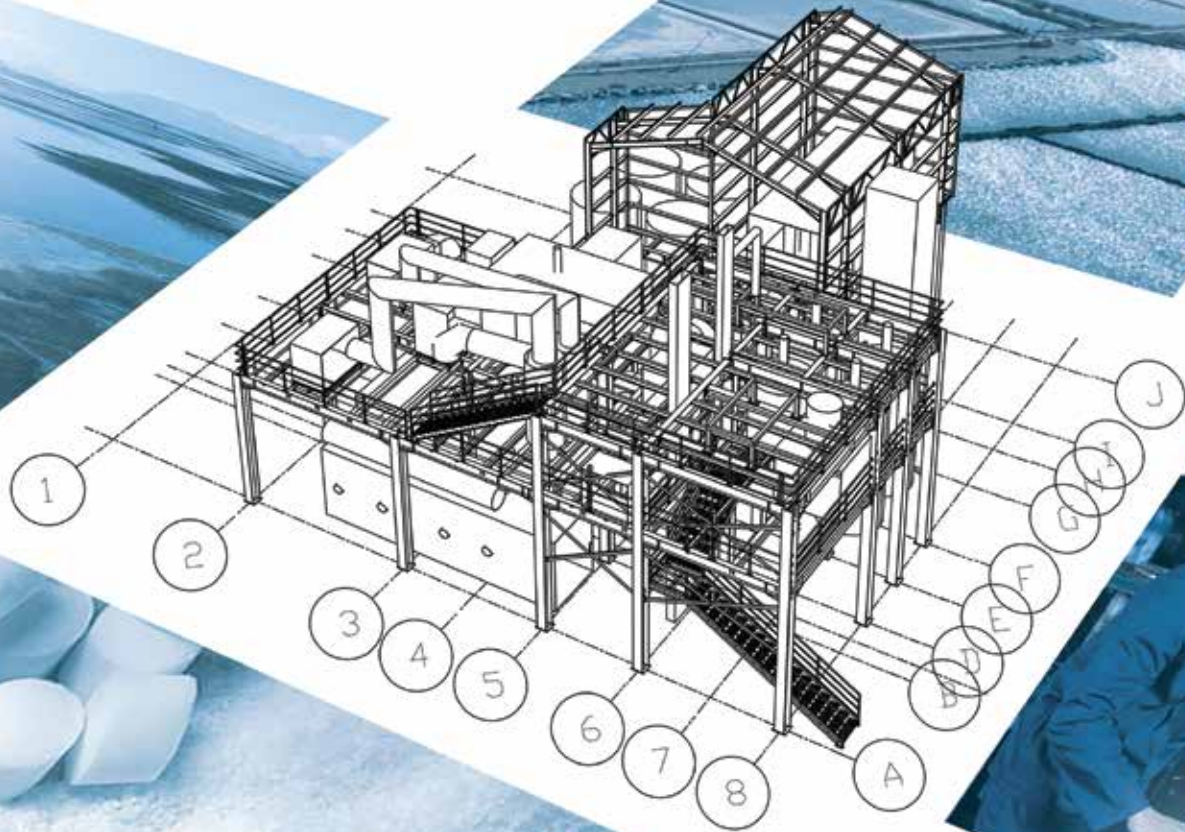

the wisdom of nature optimized by state of the art technology





the wisdom of
nature
optimised by state of the art
technology

Lublia Sea Salt Plants is a Cyprus based specialist company with expertise, resources and a successful track record in the development of exceptional sea salt projects.





knowhow
resources
passion
solutions



our strengths

- ◆ extensive salt industry knowhow from 6 decades of development
- ◆ simple procedures for fast delivery of solutions
- ◆ exact customer needs met according to available raw materials

our mission

- ◆ to deliver the most smart and efficient solutions possible
- ◆ to offer total customer satisfaction at every stage, from planning to implementation
- ◆ to always offer maximum cost efficiency in relation to available budget
- ◆ to ensure the highest health, safety and environment protection standards
- ◆ to always be a step ahead in salt harvesting and processing methods

our values

- ◆ personal service whatever the size of the project
 - ◆ a partnership culture and results driven approach
 - ◆ business ethic, integrity and long term relationships built on trust
 - ◆ respect for nature and the environment
- 

since 1967

we have been proudly pioneering
salt industry developments

In the Mediterranean island of Cyprus, during the first half of the twentieth century, salt expeditions were covered from Larnaka's only solar salt work and catered for the local needs. A great part of the local community of Larnaka was involved in the collection and merchandising of salt, which was often stimulating for the growth of the city.

In 1967 Paraskevas Theodorou, a contactor in the saline, started buying some quantities of salt, grinding, packaging and selling them. In this way he could work all year round.

His son, Michalakis Theodorou, expanded the small workshop into a small business, by building in 1979 a factory in the Industrial Area of Aradippou outside Larnaka. From this humble start, producing one ton of salt per hour, the company developed through new contemporary technology and the passion of its people, managing to increase its production and pioneer new production methods which led to new products, appealing to international markets.

In the 21st century the small family business becomes a technologically advanced group that is today recognised for its quality products and proven solutions, offered to the salt industry internationally.



today

we proudly deliver solutions
that make a tangible difference

“

In our first two decades we have built our reputation on the quality of our products.

During this time we have pioneered new production methods and developed solutions that have generated great interest among other salt producers worldwide.

Today we are sharing this expertise, remaining humble servants of nature and dedicated partners to our clients.

But despite the many technological advances we basically remain a traditionally oriented business primarily focused on our clients and a better environment.

And because we want to make a difference, we adopt a results driven approach based on accountability.

”



Michalakis Theodorou
Founder

Michalakis Theodorou was born in 1955 in Larnaka, a Cyprus coastal city famous for its landmark salt lake.

His father was a contractor during the salt lake's production days in the 1960s. As Michalakis began to grow, so did his love for salt and his lifetime job, which for him is still a journey of discovery.

In 1982 he established M.P.Theodorou Salt Industry & Co Ltd.

In 2000 he began to offer knowhow and other services to salt producers building their production plants.

In 2006 he established Lublia Trading, a specialist company with the capability of exporting this knowhow worldwide.

With an open minded approach he is today widely regarded as a pioneer in the field, always looking to improve and stay ahead in providing optimum solutions for the production of superior natural products.



the problem

The dirty parts that raw sea salt contains after harvesting are the main obstacles towards achieving a top quality result.

This could be small stones, sand, dust or other elements such as magnesium, calciums, sulphates etc, that are also collected and piled up together with the salt.

Removing these impurities out of the sea salt during the washing process has proved a very difficult task for the Salt companies.



stones



sand & dust



other salts

the solution

Lublia has the expertise, deriving from years of experience, and the proven solutions for streamlining and optimising these processes to achieve a superior quality product time after time.

what we can do

- ◆ Design and Construction of Salines
- ◆ Upgrading and Optimisation of Salines
- ◆ Design and Construction of Sea Salt harvesting machines
- ◆ Design and Manufacture of Wash units for processing Raw Material
- ◆ Design and Manufacture of Stacking Systems
- ◆ Design and Construction of Sea Salt Refinery Plants
- ◆ Upgrading and Optimisation of Sea Salt Refinery Plants
- ◆ Reconditioning and Maintenance of Salt Industry Machinery

After assessing your resources and needs we deliver optimum tailor-made solutions that will take your salt production and financial performance to another level.



“ the root of the word salt comes from the ancient Greek word ‘alas’ -initially ‘als’, meaning sea- and it was anagrammed in Latin as ‘sal’ facilitating it’s pronunciation”

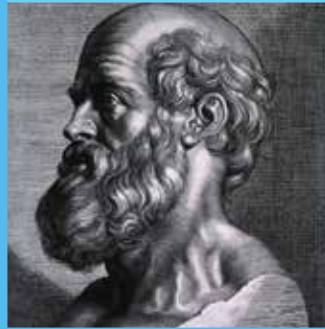

“The sun attracts the finest and lightest part of the water and carries it high up; the saltiness remains because of its thickness and weight, and in this way the salt originates”

Hippocrates

430 BC



the key benefits

First and foremost the solutions offered by Lublia will result in an immediate difference in the quality of the final product.

Plus some other very important benefits:

- ◆ An increase in cost efficiency, increasing your profit.
- ◆ The NaCl content will increase substantially
- ◆ The losses from the cleaning process be minimized
- ◆ We have a system to separate and recover the NaCl losses.
- ◆ No added chemicals to clean the salt, as everything goes through mechanical methods

looking after



our environment

When undertaking a project for the creation of salines we see ourselves as assisting nature to give us the purest possible salt product in the most environment-friendly way.

And from study to implementation we are governed by the following principles:

...We are actually creating an ideal eco-system

...The surrounding area remains totally unaffected

...The saline is protected by other possible industrial developments in the area

...Not only we protect bio-diversity but we even manage to increase it

...The sea-saline flora and fauna is preserved



The result is an organic part of nature that retains its original natural harmony with the added bonus of becoming productive and profitable.

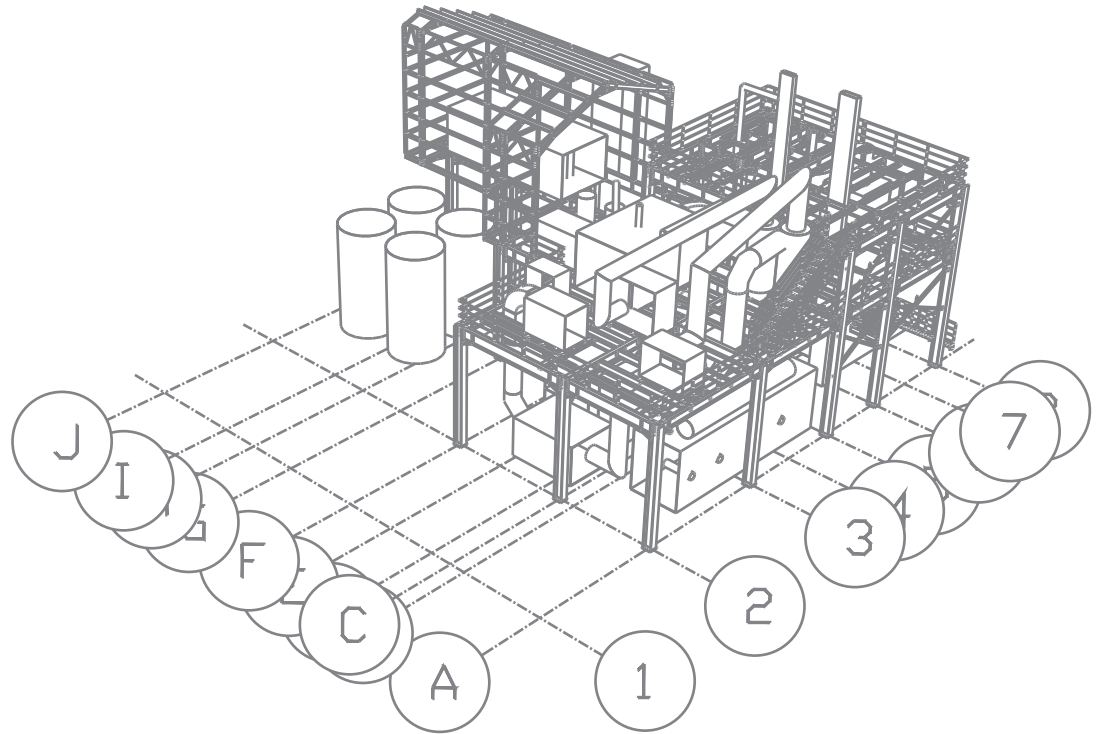
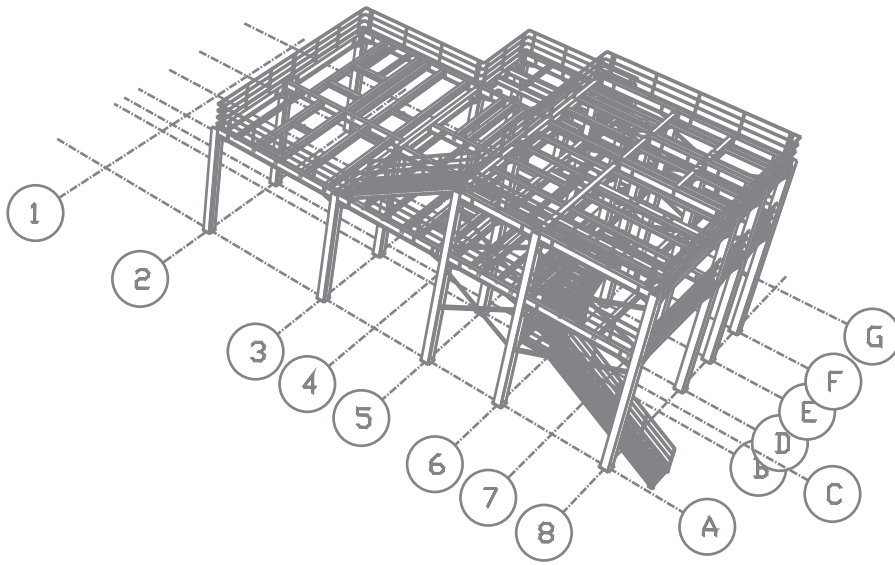

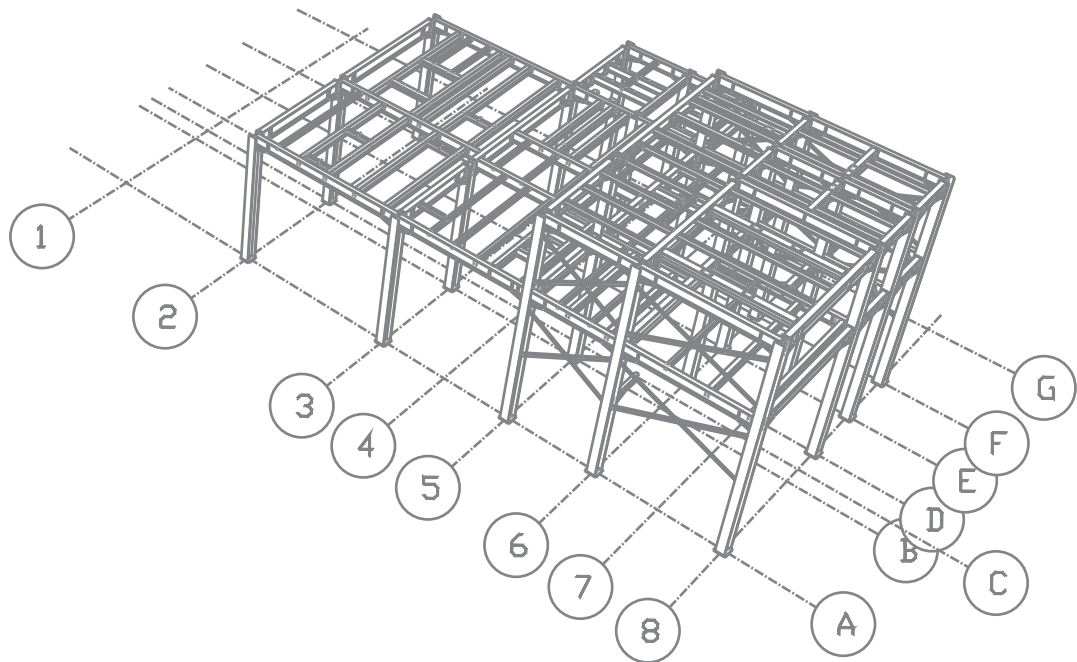
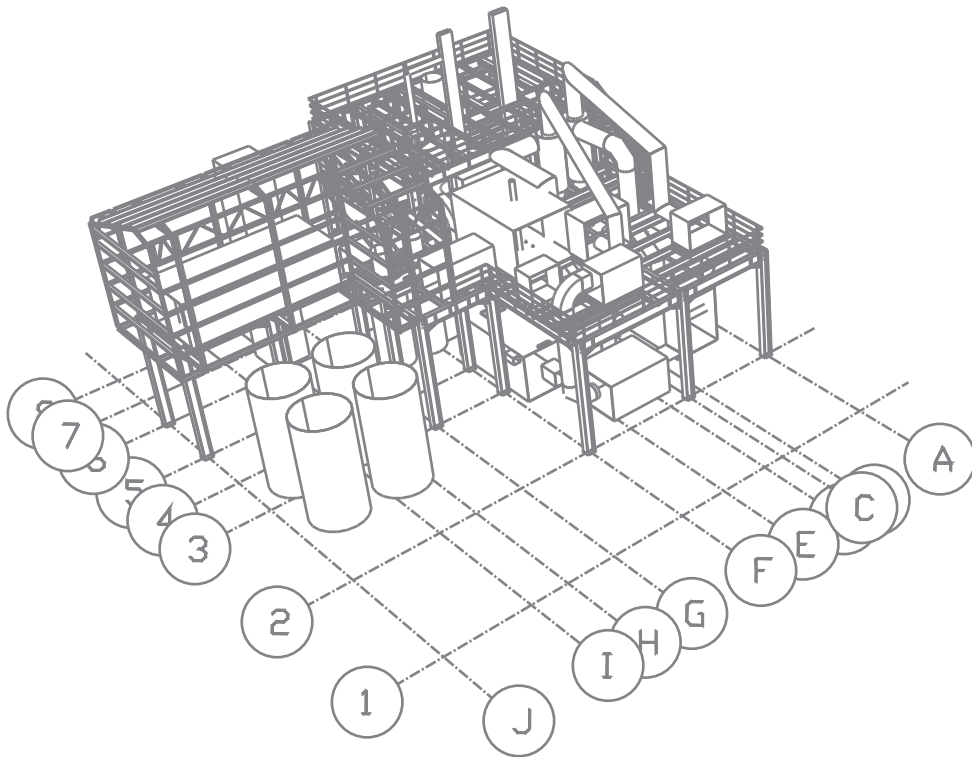

contact

Larnaka Industrial Estate, P.O.Box 42586
6500 Larnaka Cyprus.
tel. 00357 24 533168, fax. 00357 24 530528
email: info@lublia.com
web: www.lublia.com